

SMD DOWNLIGHTS / BT PANEL

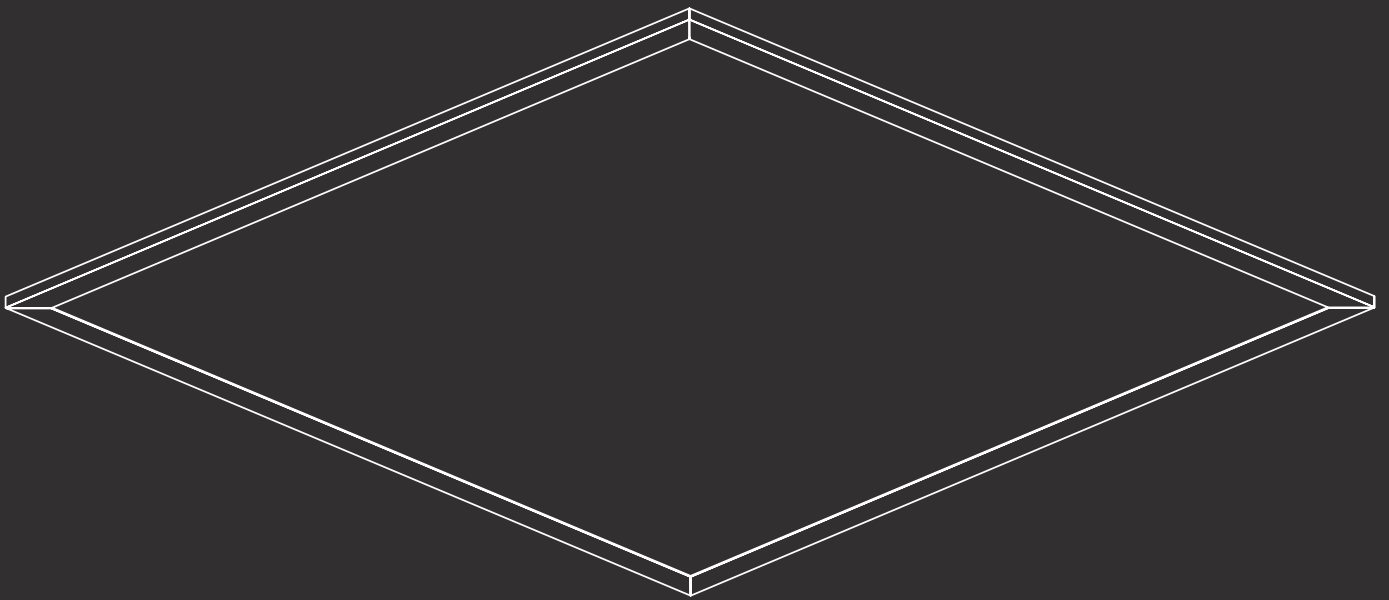

Clight

BT PANEL

SMD Downlight



BT PANEL is an ideal lighting solution for commercial spaces such as offices, schools, hospitals, and supermarkets. This high-quality and durable backlight panel provides uniform lighting with no yellowing problem. It's energy-efficient, cost-effective, and comes in different color temperatures to suit any project that requires a high-quality and uniform light source.

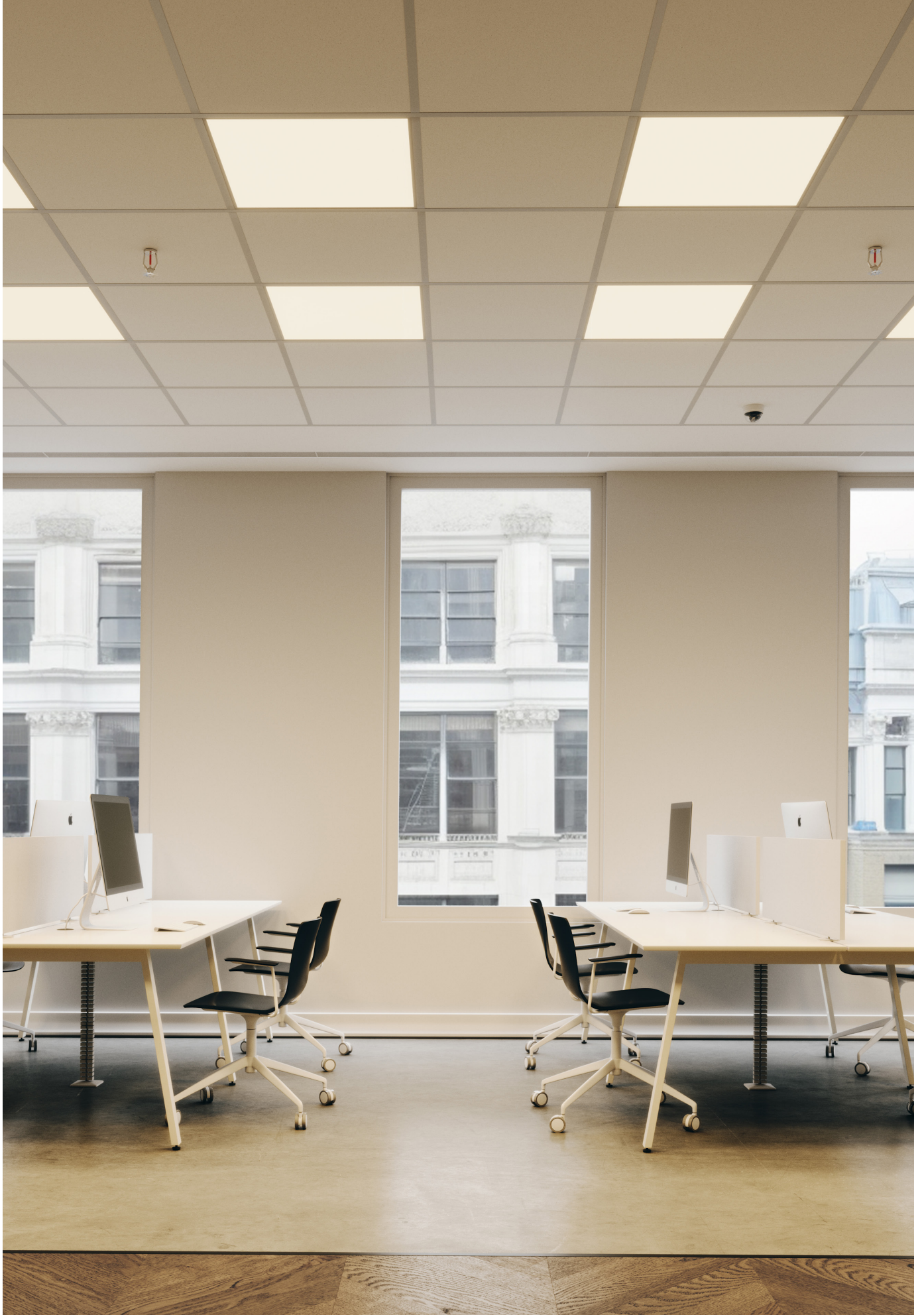



- Uniform light effect with optical lens
- Interchangeable CCT (3000K + 4000K + 5700K) with slide switch
- Integrated iron plate design provides excellent thermal management
- Ultra slim, 25mm only
- Built-out driver



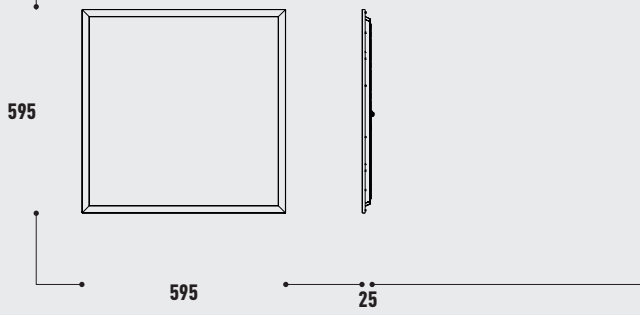

LED	lm	K	W	OUTPUT mA	OPTIC	CUT OUT mm	Type	Dimming	Colour	Item no.
SMD	3600	3000 4000 5700	36	900	120°	-	•	TRIAC*	White	15518

* not included



CARTON	Size (L*W*H) cm	PCS	CBM	kg
•	67.5*20*62	6	0.084	8.4

HEADQUARTER

Hatnufa 7 St.
9342207 Jerusalem
Israel

LOGISTIC CENTER

Tsela ha-Har St. 47
7178127 Modein
Israel

T +972 (2) 6727811/2

F +972 (2) 6727813

office@clight-led.com
export@clight-led.com

Clight

by **Cabasso Group**