

# SMD DOWNLIGHTS / COSTA

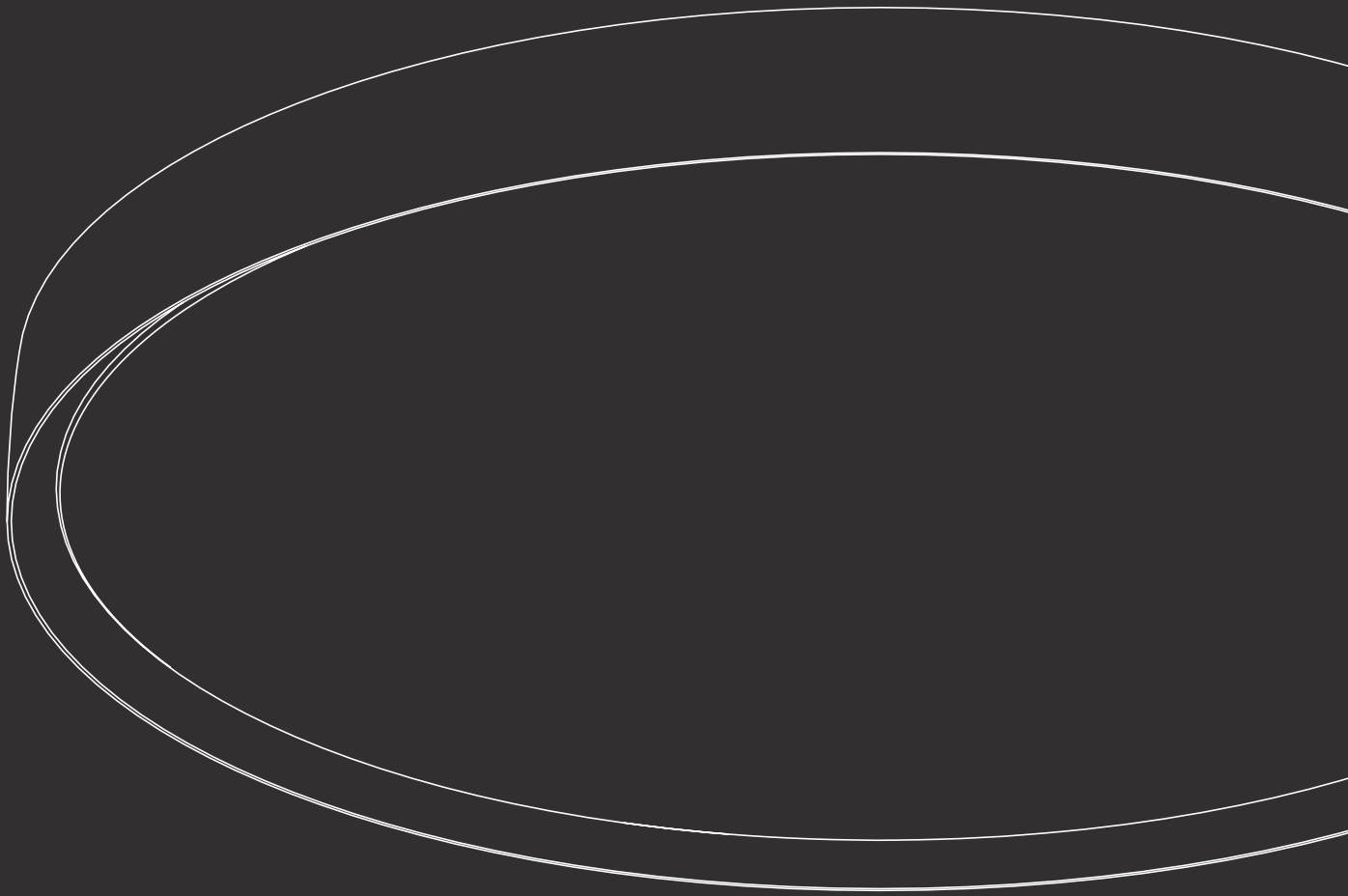

Clight

# COSTA



## SMD Downlight

The COSTA series, available in diameters of 40cm, 60cm, and 80cm, epitomizes technical precision and design harmony. Each fixture provides uniform, wide-angle luminescence with minimal shadowing, due to its superior LED technology. Ideal for a spectrum of applications, COSTA ensures energy-efficient, high-quality lighting solutions for both residential and commercial environments.







- Surface light
- High quality diffuser
- Integrated SMD backlight
- Aluminum body
- CRI  $\geq 80$

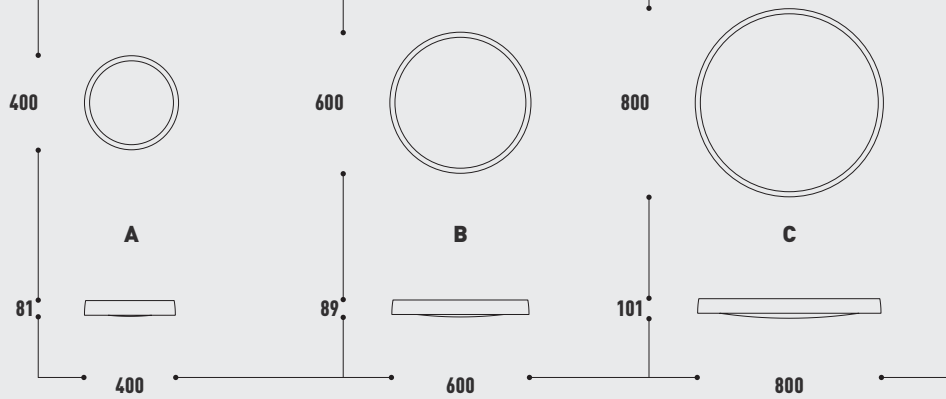

LED	lm	K	W	INPUT mA	OPTIC	CUT OUT mm	Type	Colour	Item no.
SMD	1580	3000	30	750	90°	-	A	White	15450
								Black	15451
								White/Gold	15452
SMD	3200	3000	60	2x750	90°	-	B	White	15453
								Black	15454
								White/Gold	15455
SMD	5200	3000	100	2x1200	90°	-	C	White	15456
								Black	15457
								White/Gold	15458

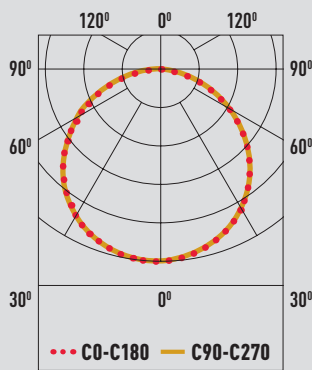

DIAM	LUX	DIST	
4.2 m	303 lx	1.5 m	A
3.1 m	1185 lx	1.0 m	B
4.4 m	1248 lx	1.5 m	C
6.3 m	135 lx	2.3 m	
6.2 m	296 lx	2.0 m	
6.5 m	555 lx	2.3 m	
9.9 m	56 lx	3.5 m	
9.4 m	132 lx	3.0 m	
10.1 m	229 lx	3.5 m	
11.3 m	43 lx		
12.5 m	74 lx		
11.6 m	176 lx	4.0 m	



CARTON	Size (L*W*H) cm	PCS	CBM	kg
A	45*45*45	4	0.091	8
B	65*65*10.5	1	0.044	4.65
C	86*86*10.5	1	0.078	8

**HEADQUARTER**

Hatnufa 7 St.  
9342207 Jerusalem  
Israel

**LOGISTIC CENTER**

Tsela ha-Har St. 47  
7178127 Modein  
Israel

T +972 (2) 6727811/2

F +972 (2) 6727813

office@clight-led.com  
export@clight-led.com

**Clight**  
by **Cabasso Group**