

SMD DOWNLIGHTS / BRI

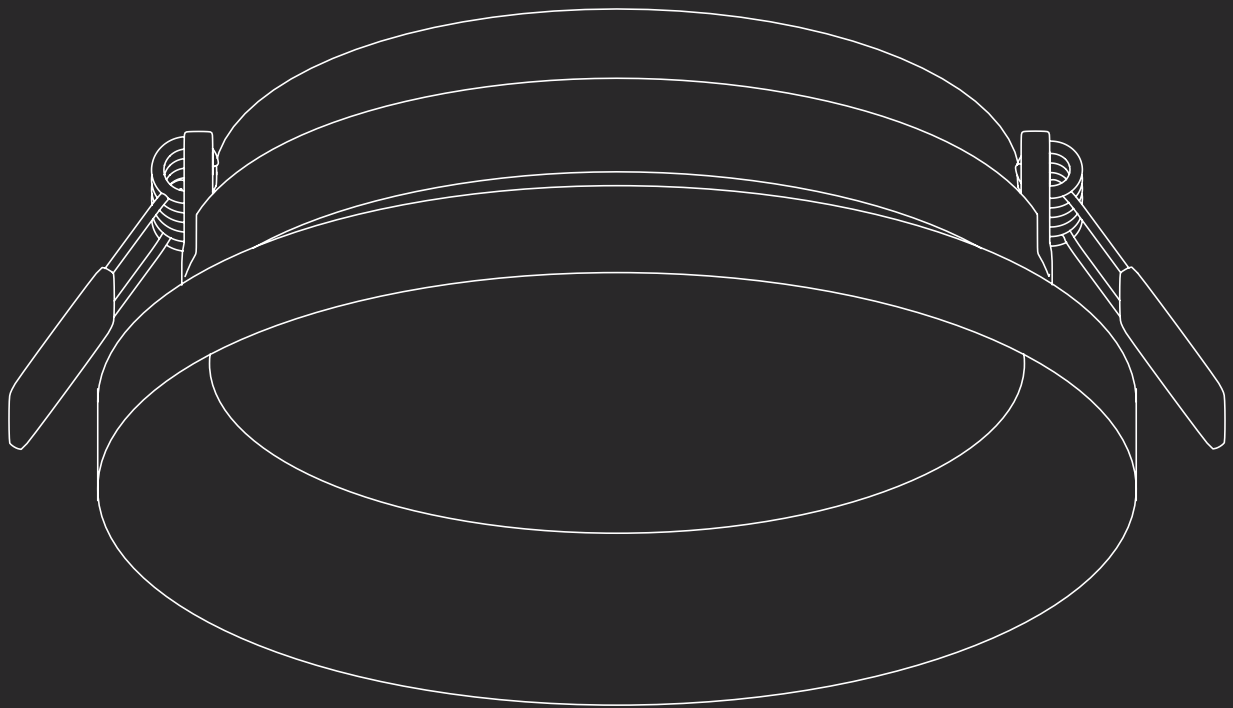

Clight

BRI



SMD Downlight

A modern and elegant design, which complements the surrounding style. These recessed downlights create uniform light distribution for use in general lighting applications. The depth creates an anti glare effect. Available in three sizes.



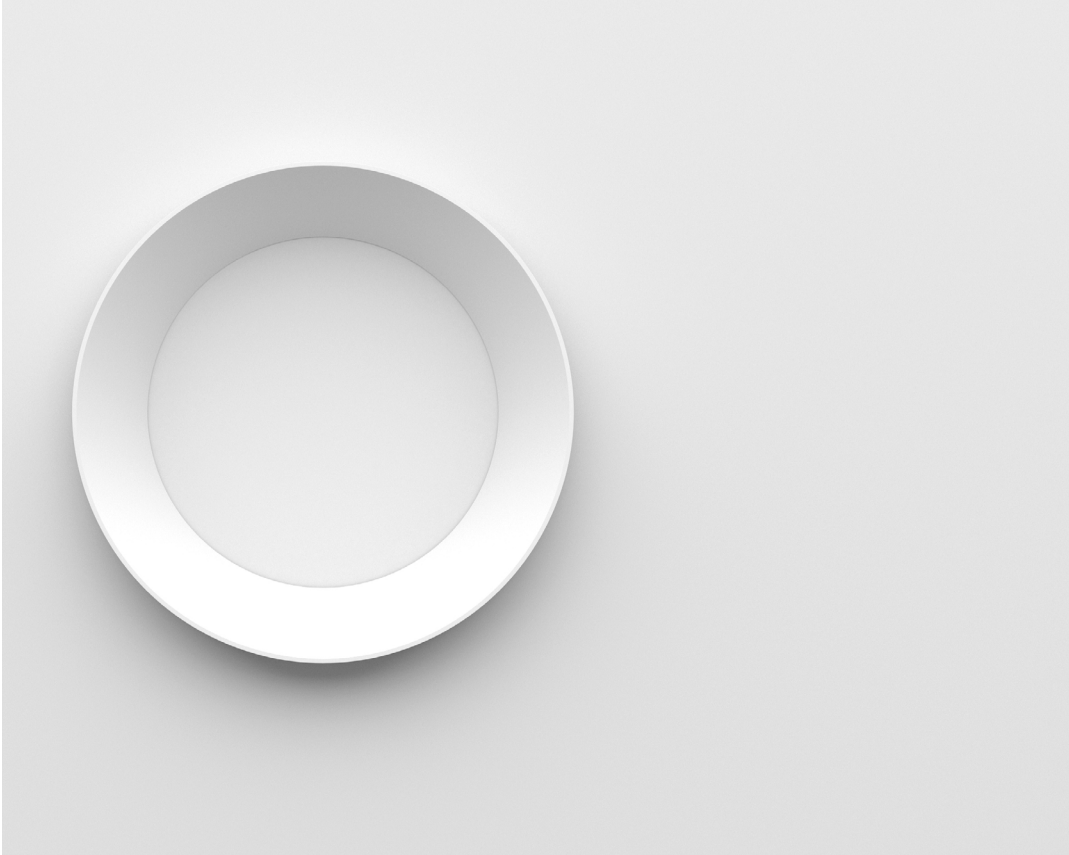

- High quality diffuser
- Integrated SMD backlight
- Bold aluminum frame



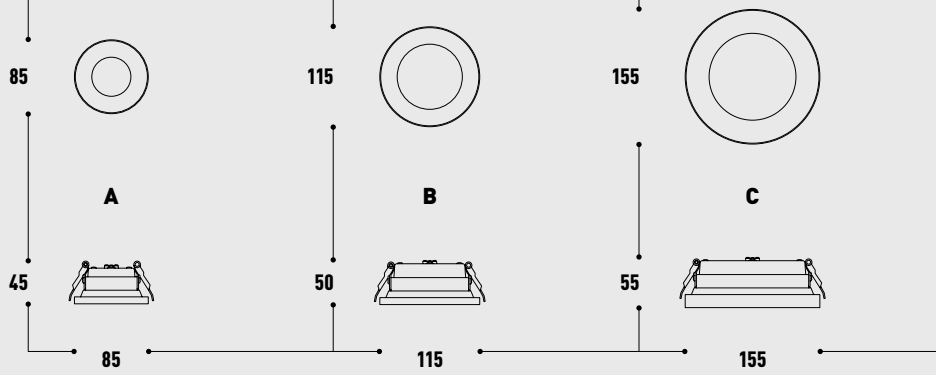

LED	lm	K	W	INPUT mA	OPTIC	CUT OUT mm	Type	Colour	Item no.
SMD	270	3000	3.5	350	90°	75	A	White	15001
								Black	150011
SMD	1125	3000	11	350	94°	105	B	White	15002
								Black	150022
SMD	1725	3000	17	350	92°	145	C	White	15003
								Black	150033

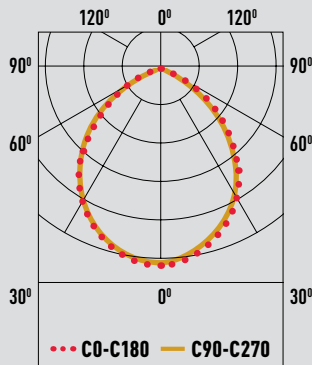

DIAM	LUX	DIST
2.0 m	139 lx	1 m
2.2 m	467 lx	
2.1 m	560 lx	
4.1 m	35 lx	2 m
4.3 m	117 lx	
4.3 m	140 lx	
6.1 m	15 lx	3 m
6.5 m	52 lx	
6.3 m	62 lx	
8.1 m	9 lx	4 m
8.6 m	29 lx	
8.4 m	35 lx	

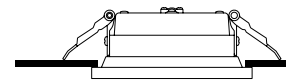

CARTON	Size	PCS	CBM	kg
	(L*W*H) cm			
A	47.5*38*24.5	60	0.044	10.8
B	50*26*32	40	0.041	12.4
C	50*34*37	30	0.062	12.4

HEADQUARTER

Hatnufa 7 St.
9342207 Jerusalem
Israel

LOGISTIC CENTER

Tsela ha-Har St. 47
7178127 Modein
Israel

T +972 (2) 6727811/2

F +972 (2) 6727813

office@clight-led.com
export@clight-led.com

Clight

by **Cabasso Group**